

## Husky™ 205 Air–Operated Diaphragm Pumps

308652V

100 psi (0.7 MPa, 7 bar) Maximum Incoming Air Pressure  
100 psi (0.7 MPa, 7 bar) Maximum Fluid Working Pressure



### Important Safety Instructions.

Read all warnings and instructions in this manual.  
Save these instructions.

### Part No. D120XX

Polypropylene Pump with Air–Operated Motor

### Part No. D110XX and DM10XX

Acetal Pump with Air–Operated Motor



### Part No. D150XX and DM50XX

PVDF Pump with Air–Operated Motor

### Part No. D220XX

Polypropylene Pump with Solenoid Ports

### Part No. D210XX

Acetal Pump with Solenoid Ports



### Part No. D250XX

PVDF Pump with Solenoid Ports

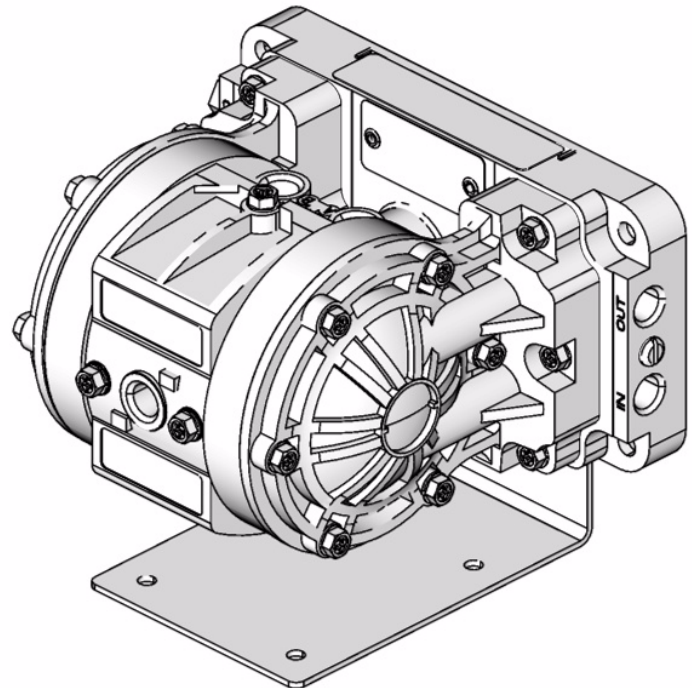

ti10660a

Patent No.  
CH ZL01113998.6  
EU 0942171  
US 5,860,794  
AR AR006617B1  
KP 461707  
CH ZL01124998.6  
BR PI9701779\_5

GRACO INC. P.O. BOX 1441 MINNEAPOLIS, MN 55440-1441  
Copyright 1996, Graco Inc. is registered to I.S. EN ISO 9001

PROVEN QUALITY. LEADING TECHNOLOGY.



# Contents

Warnings .....	2
Installation .....	4
Operation .....	8
Maintenance .....	9
Troubleshooting .....	10
Service .....	12
Parts Matrix .....	15
Service Kit Matrix .....	15
Parts Lists .....	16
Parts Drawing .....	17
Torque Sequence .....	18
Technical Data .....	19
Dimensions and Mounting Hole Layout .....	20
Performance Charts .....	21
Graco Standard Warranty .....	24
Graco Information .....	24

## Warning Symbol



This symbol alerts you to the possibility of serious injury or death if you do not follow the instructions.

## Caution Symbol



This symbol alerts you to the possibility of damage to or destruction of equipment if you do not follow the instructions.

# ! WARNING



INSTRUCTIONS

## EQUIPMENT MISUSE HAZARD

Any misuse of the equipment or accessories, such as overpressurizing, modifying parts, using incompatible chemicals and fluids, or using worn or damaged parts, can cause them to rupture and result in splashing in the eyes or on the skin, other serious injury, or fire, explosion or property damage.

- This equipment is for professional use only. Observe all warnings. Read and understand all instruction manuals, warning labels, and tags before you operate this equipment. If you are not sure, or if you have questions about installation or operation, call your Graco distributor.
- Never alter or modify any part of this equipment; doing so could cause it to malfunction. Use only genuine Graco part numbers and accessories.
- Check all equipment regularly and repair or replace worn or damaged parts immediately.
- Never exceed the recommended working pressure or the maximum air inlet pressure stated on your pump or in the **Technical Data** on page 19.
- Do not exceed the maximum working pressure of the lowest rated component in your system. This equipment has a **100 psi (0.7 MPa, 7 bar) maximum working pressure at 100 psi (0.7 MPa, 7 bar, ) maximum incoming air pressure.**
- Be sure that all fluids and solvents used are chemically compatible with the wetted parts shown in the **Technical Data** on page 19. Always read the manufacturer's literature before you use fluid or solvent in the pump.
- Never move or lift a pump under pressure. If dropped, the fluid section may rupture. Always follow the **Pressure Relief Procedure** on page 8 before you move or lift the pump.
- **Never** use a polypropylene or PVDF pump with non-conductive flammable fluids as specified by your local fire protection code. Refer to **Grounding** on page 4 for additional information. Consult your fluid supplier to determine the conductivity or resistivity of your fluid.
- Provide fresh air ventilation to avoid the buildup of flammable fumes from solvents or the fluid being pumped.

# WARNING



## HAZARDOUS FLUIDS

Improper handling of hazardous fluids or inhaling toxic vapors can cause extremely serious injury or death from splashing in the eyes, ingestion, or bodily contamination. Observe all the following precautions when you handle hazardous or potentially hazardous fluids.

- Know what fluid you are pumping and its specific hazards. Take precautions to avoid a toxic fluid spill.
- Always wear appropriate clothing and equipment, such as eye protection and breathing apparatus, to protect yourself.
- Store hazardous fluid in an appropriate, approved container. Dispose of it according to all Local, State, and Federal guidelines for hazardous fluids.
- Secure the fluid outlet hose tightly into the receiving container to prevent it from coming loose and improperly draining the fluid.
- Pipe and dispose of the exhaust air safely, away from people, animals, and food handling areas. If the diaphragm fails, the fluid is exhausted along with the air. See **Air Exhaust Ventilation** on page 5.



## FIRE AND EXPLOSION HAZARD

Static electricity is created by the flow of fluid through the pump and hose. If the equipment is not properly grounded, sparking may occur. Sparks can ignite fumes from solvents and the fluid being pumped, dust particles, and other flammable substances, whether you are pumping indoors or outdoors, and can cause a fire or explosion and serious injury and property damage.

- To reduce the risk of static sparking, ground the pump and all other equipment used or located in the work area. Check your local electrical code for detailed grounding instructions for your area and type of equipment. See **Grounding** on page 4.
- If you experience any static sparking or even a slight shock while using this equipment, **stop pumping immediately**. Check the entire system for proper grounding. Do not use the system again until you have identified and corrected the problem.
- Pipe and dispose of the exhaust air safely, away from all sources of ignition. If the diaphragm fails, the fluid is exhausted along with the air. See **Air Exhaust Ventilation** on page 5.
- Do not smoke in the work area. Do not operate the equipment near a source of ignition or an open flame, such as a pilot light.

United States Government safety standards have been adopted under the Occupational Safety and Health Act. You should consult these standards—particularly the General Standards, Part 1910, and the Construction Standards, Part 1926.

# Installation

## Tightening Threaded Fasteners Before First Use

Before using the pump for the first time, check and retorque all external fasteners. See **Torque Sequence**, page 18. After the first day of operation, retorque the fasteners. Although pump use varies, a general guideline is to retorque fasteners every two months.

Use a compatible thread sealant on all male threads. Tighten all connections firmly to avoid air or fluid leaks.

### CAUTION

To avoid pump damage, do not overtighten the fittings to the pump.

## Grounding

### WARNING



#### FIRE AND EXPLOSION HAZARD

This pump must be grounded. Before you operate the pump, ground the system as explained below. Also read the section **FIRE AND EXPLOSION HAZARD** on page 3.



The *acetal pump* contains stainless steel fibers which make the wetted parts conductive. Attaching the ground wire to one of the grounding locations grounds the wetted parts.

The *polypropylene and PVDF pumps* are **not** conductive. When you pump conductive flammable fluids, **always** ground the entire fluid system by making sure the fluid has an electrical path to a true earth ground. See Fig. 1. **Never** use a polypropylene or PVDF pump with non-conductive flammable fluids as specified by your local fire protection code. Consult your fluid supplier to determine the conductivity or resistivity of your fluid.

US Code (NFPA 77 Static Electricity) recommends a conductivity greater than  $50 \times 10^{-12}$  Siemens/meter (mhos/meter) over your operating temperature range to reduce the hazard of fire. Consult your fluid supplier to determine the conductivity or resistivity of your fluid. The resistivity must be less than  $2 \times 10^{12}$  ohm-centimeters.

To reduce the risk of static sparking, ground the pump and all other equipment used or located in the pumping area. Check your local electrical code for detailed grounding instructions for your area and type of equipment.

### Acetal Pump Grounding Instructions

**For polypropylene and PVDF pumps, see the warning above.**

**Ground all of this equipment.**

*Pump:* Connect a ground wire (A) and clamp, Part No. 222011. See Fig. 1. The pump grounding locations are on the manifold between the inlet and outlet ports. Use the nut (B) and bolt (C) that are provided with the pump, and install as follows:

1. Place the nut in the nut catcher on the underside of the manifold.
2. Insert the bolt through the loop end of the ground wire.
3. Insert the bolt through the hole on the pump manifold and tighten it into the nut that you positioned in step 1.
4. Connect the clamp end of the ground wire to a true earth ground.

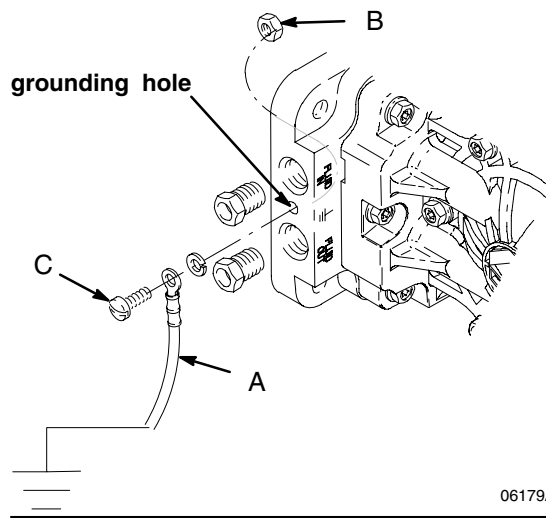

Fig. 1

06179A

- *Air and fluid hoses:* Use only grounded hoses with a maximum of 500 ft (150 m) combined hose length to ensure grounding continuity.
- *Air compressor:* Follow the manufacturer's recommendations.
- *All solvent pails used when flushing:* Follow the local code. Use only grounded metal pails, which are conductive. Do not place the pail on a non-conductive surface, such as paper or cardboard, which interrupts the grounding continuity.
- *Fluid supply container:* Follow the local code.

# Installation

## Air Exhaust Ventilation

### WARNING



#### TOXIC FLUID HAZARD

Read the **USING HAZARDOUS FLUIDS** and **FIRE AND EXPLOSION HAZARD** sections on page 3 before you operate this pump.



Be sure the system is properly ventilated for your type of installation. You must vent the exhaust to a safe place, away from people, animals or food handling areas when pumping flammable or hazardous fluids.



If the diaphragm ruptures, the fluid being pumped is exhausted with the air. Place a container at the end of the air exhaust line to catch fluid in case the diaphragm ruptures, and disconnect the pump.

## Mountings

### CAUTION

The pump exhaust air may contain contaminants. If needed, ventilate to a remote area to reduce possible fluid contamination. See **Air Exhaust Ventilation** on page 5.

- **Mounting Bracket:**

The pump is shipped with a 90 degree mounting bracket (60). Mount the pump to the bracket using the four screws (61) provided. Secure the opposite portion of the mounting bracket to a horizontal surface. The mounting bracket must be used for proper pump performance.

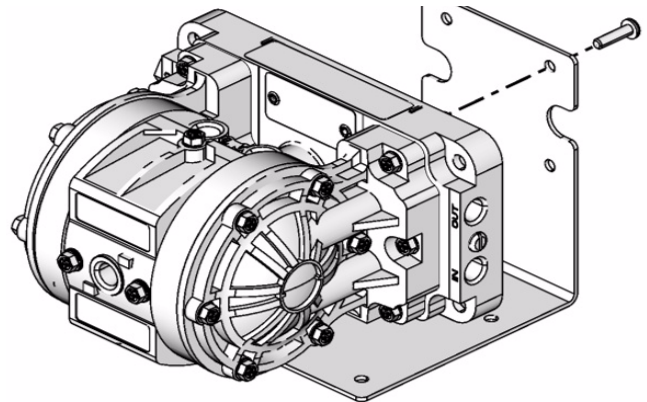

Fig. 2

ti10662a

- Be sure the mounting can support the weight of the pump, hoses, and accessories, as well as the stress caused during operation.
- For all mountings, be sure the pump is secured with screws and nuts.

### WARNING

To reduce the risk of serious injury, splashing in the eyes or on the skin, and toxic fluid spills, **never** move or lift a pump under pressure. If dropped, the fluid section may rupture. Always follow the **Pressure Relief Procedure** on page 8 before you move or lift the pump.

# Installation

## Air Lines

### **⚠ WARNING**

#### **Bleed-Type Master Air Valve and Fluid Drain Valve**

A bleed-type master air valve and a fluid drain valve are required on your system.

The bleed-type master air valve relieves air trapped between itself and the pump. Trapped air can cause the pump to cycle unexpectedly, which could result in serious bodily injury, including splashing in the eyes, injury from moving parts, or contamination from hazardous fluids.

The fluid drain valve reduces the risk of serious bodily injury, including splashing in the eyes or on the skin, or contamination from hazardous fluids. Install the fluid drain valve close to the pump's fluid outlet to relieve pressure in the hose if the hose becomes plugged.

1. Mount the air line accessories on the wall or on a bracket. Be sure the air line supplying the accessories is grounded.
  - a. The pump speed can be controlled in one of two ways: To control it on the air side, install an air regulator. To control it on the fluid side, install a fluid valve near the outlet.
  - b. Install a bleed-type master air valve downstream from the air regulator, and use it to relieve trapped air. See the **Bleed-Type Master Air Valve and Fluid Drain Valve** warning above. Locate another bleed-type master air valve upstream from all air line accessories, and use it to isolate the accessories during cleaning and repair.
  - c. The air line filter removes harmful dirt and moisture from the compressed air supply.
2. Install a flexible air hose between the accessories and the pump air inlet. Screw the air line fitting into the air inlet.
3. Do not restrict the exhaust port. Excessive exhaust restriction can cause erratic pump operation.

## Fluid Lines

Fig. 3. On each end of the fluid manifold are a fluid IN port and a fluid OUT port. **NOTE: Make sure the fluid OUT port on the fluid manifold is mounted up.** This will assure proper pump priming. Fluid-in and fluid-out lines can be connected on the same end, or opposite ends of the manifold. Plug ports that are not used (plugs provided).

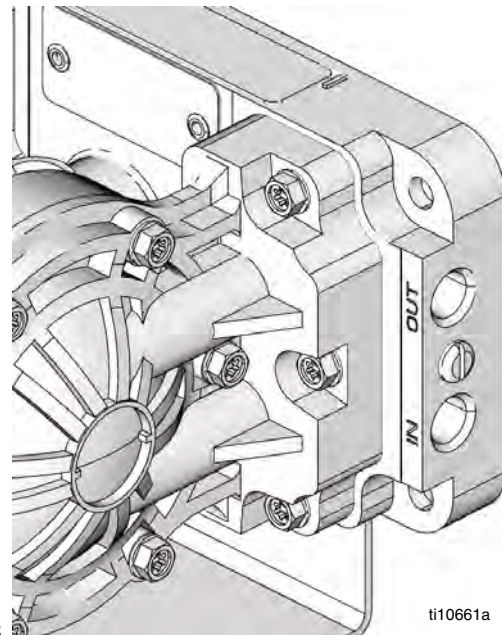

Fig. 3

## Typical Installation

The installations shown in Fig. 4 are only a guide to help select and install a pump; they are not actual system designs.

Typical installation includes (not supplied by Graco):

- For solenoid operation: a four-way, 5-port, 3-position solenoid valve with 1/4-in. ports, or two 3-position 3-way valves. Mac series 44 (4-way), or series 35 (3-way). Either way, air pressure should be released if not cycling.
- PLC or timer. Consult your local industrial controls distributor.

### **⚠ CAUTION**

For solenoid operation, the pump must exhaust through the solenoid. Failure to exhaust through solenoid could cause the diaphragms to fail.

# Installation

## KEY

- A Husky 205 pump
  - B Bleed-type master air valve (required for pump)
  - C Air line(s)
  - E Master air valve (for accessories)
  - F Air line filter
  - G Muffler
  - H Pump air regulator
  - J Fluid drain valve (required on fluid outlet side of pump)
  - L Fluid suction line
  - N Fluid supply hose
  - T Bung adapter
  - U 4-way solenoid
  - Y Ground wire (required)
- See page 4 for installation instructions.

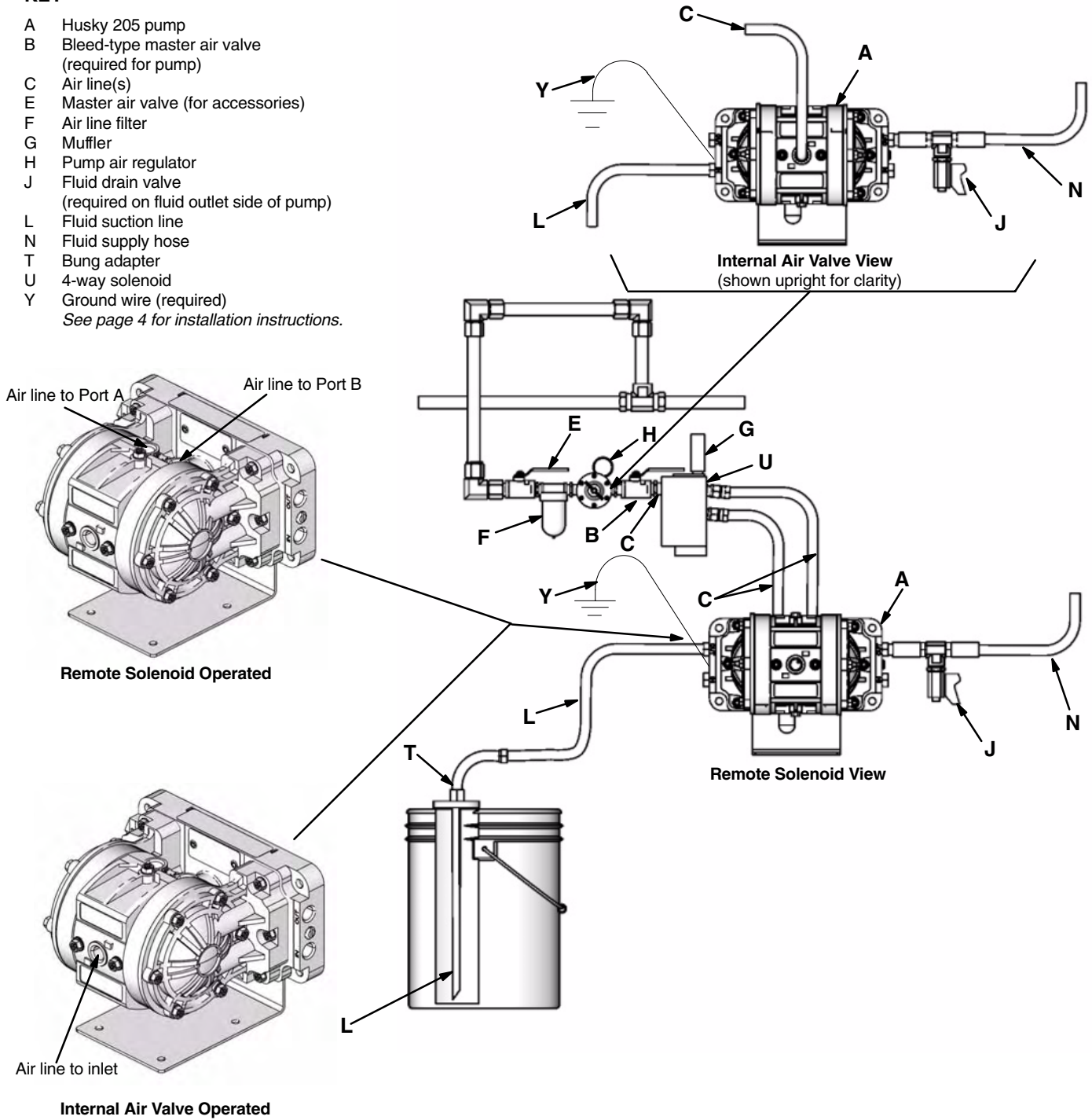

Fig. 4

ti10663a

# Operation

## Pressure Relief Procedure

### **WARNING**

To reduce the risk of serious injury, including splashing fluid in the eyes or on the skin, follow this procedure whenever you are instructed to relieve pressure, when you shut off the pump, and before you check, adjust, clean, move, or repair any system equipment.

1. Shut off air and reserve air to the pump.
2. Open the dispensing valve if the system has one.
3. Open the fluid drain valve to relieve all system pressure, and have a container ready to catch the drainage.

## Flushing the Pump Before First Use

The pump was tested in water. If water could contaminate the fluid you are pumping, flush it thoroughly with a compatible solvent. Follow the procedure in **Starting and Adjusting the Pump**.

## Starting and Adjusting the Pump

### **WARNING**

To reduce the risk of serious injury, splashing in the eyes or on the skin, and toxic fluid spills, **never** move or lift a pump under pressure. If the pump is dropped, the fluid section could rupture. Always follow the **Pressure Relief Procedure** above before you move or lift the pump.

1. Be sure the pump is properly grounded. Read and follow the instructions in **Grounding** on page 4.
2. Check all fittings to be sure they are tight. Be sure to use a compatible liquid thread sealant on all male threads. Tighten the fluid inlet and outlet fittings and plugs securely. Retorque all fasteners before start-up. See **Torque Sequence**, page 18.

3. Place the suction tube (if used) in the fluid to be pumped.
4. Place the end of the outlet hose into an appropriate container.
5. Close the fluid drain valve.
6. With the air regulator closed, open all bleed-type master air valves.
7. If the outlet hose has a dispensing device, hold it open while continuing with step 8.
8. Slowly open the air regulator until the pump starts to cycle. Allow the pump to cycle until all air is pushed out of the lines and the pump is primed.

**NOTE:** To prime a remote solenoid-operated air valve, operate the pump at a minimum 60 cpm rate until the pump is fully primed.

## Pump Shutdown

At the end of the work shift, and before you check, adjust, clean, or repair the system, **relieve air and fluid pressure**.

### **WARNING**

To reduce the risk of serious injury whenever you are instructed to relieve pressure, always follow the **Pressure Relief Procedure** at left.



# Maintenance

## Lubrication

The air valve is lubricated at the factory and designed to operate without additional lubrication.

If added lubrication is desired, every 500 hours of operation (or monthly), remove the hose from the pump air inlet and add two drops of machine oil to the air inlet.

### CAUTION

Do not over-lubricate the pump. Excess oil is exhausted through the muffler, which could contaminate your fluid supply or other equipment.

## Tightening Threaded Connections

Before each use, check all hoses for wear or damage, and replace as necessary. Be sure all threaded connections are tight and free of leaks.

Check fasteners. Tighten or retorque as necessary. Although pump use varies, a general guideline is to retorque fasteners every two months. See **Torque Sequence**, page 18.

## Flushing and Storage

Flush the pump to prevent the fluid from drying or freezing in the pump and damaging it. Always flush the pump and **relieve the pressure** before storing for any length of time. Use a compatible solvent.

### WARNING

To reduce the risk of serious injury whenever you are instructed to relieve pressure, always follow the **Pressure Relief Procedure** on page 8.

*If you are flushing*, run the pump long enough to thoroughly clean the pump and hoses, close the air regulator, and remove the suction hose from the solvent and place it in the fluid to be pumped.

*If you are shutting down the pump*, remove the suction hose from the fluid container, run the pump until the fluid is forced out of the system, and shut off the air supply immediately.

# Troubleshooting

Relieve the pressure before you check or service the equipment.

Check all possible problems and causes before you disassemble the pump.

## ⚠ WARNING

To reduce the risk of serious injury whenever you are instructed to relieve pressure, always follow the **Pressure Relief Procedure** on page 8.

### Internal Air Valve-Operated and Remote Solenoid-Operated Pumps

PROBLEM	CAUSE	SOLUTION
The pump cycles at stall, or it fails to hold pressure at stall.	The check valves (20) or o-rings (21) are leaking.	Replace the check valves and/or o-rings. See page 14.
	The check valves (20) are worn.	Replace the check valves. See page 14.
	Debris is stuck between the a check valve (20) and the seat.	Clean the check valve/seat area. See page 14.
The pump operates erratically.	The suction line is clogged.	Inspect and clear the line.
	The check valves (20) are sticking or leaking.	Replace the check valves, or clean and check the valve/seat area. See page 14.
	A diaphragm (30) is ruptured.	Replace the ruptured diaphragm. See page 13.
There are air bubbles in the fluid.	The suction line is loose.	Tighten the suction line.
	A diaphragm (30) is ruptured.	Replace the ruptured diaphragm. See page 13.
	The manifold (52) is loose, or the o-rings (21) are damaged.	Tighten the manifold screws (58). Replace the o-rings (21). See page 14.
	The fluid covers (51) are loose.	Tighten the fluid cover screws (58). See page 13.
There is fluid in the exhaust air.	A diaphragm (30) is ruptured.	Replace the ruptured diaphragm. See page 13.
	A diaphragm plate (50) is loose.	Tighten the diaphragm plate. See page 13.
The pump exhausts air near the fluid covers.	The fluid covers (51) are loose, or the o-rings (57) are damaged.	Tighten the fluid cover screws (58), or replace the o-rings. See page 13.
The pump exhausts air near the air valve.	The air valve cover screws (14) are loose.	Tighten the screws. See page 12.
	The top (5) and/or side (6) air valve o-rings are damaged.	Replace these o-rings. See the <b>Parts Drawing</b> on page 17.
The pump leaks fluid from the check valves.	The o-rings (21) are leaking, or the screws (58) are loose.	Replace these o-rings, and tighten the screws. See page 14.

# Troubleshooting

## Internal Air Valve-Operated Pumps Only

PROBLEM	CAUSE	SOLUTION
The pump will not cycle, or it cycles once and stops.	The air valve is stuck or dirty.	Disassemble and clean or repair the air valve. See page 12.  Use filtered air.
	Not enough air pressure supplied.	Increase air pressure supply. Do not exceed maximum input pressure.

## Remote Solenoid-Operated Pumps Only

PROBLEM	CAUSE	SOLUTION
The pump will not prime or loses prime.	The cycle rate is too low.	Increase cycle rate to 60 cpm.
	The check valves (20) are not sealing.	Inspect the check valves, and replace them if worn or damaged. See page 14.
	Fluid manifold not mounted with OUT port up.	Re-mount fluid manifold so OUT port is up.
The pump leaks air or does not operate.	Air is supplied to Port A and Port B at the same time.	Replace both diaphragms (30). See page 13.  Check your installation. See page 7.
	Solenoid exhaust is plugged.	Ensure that exhaust (G on page 7) is free of obstructions.

# Service

## Service Kits

Service Kits may be ordered separately.

To repair the air valve, order Part No. 238853. Parts included in the Air Valve Service Kit are marked with an asterisk in the **Parts Drawing** on page 17, for example (3\*).

For fluid section repair section parts, see the **Service Kit Matrix** on page 15. Parts included in the Fluid Section Service Kit are marked with a dagger in the **Parts Drawing** on page 17, for example (4†).

## Servicing the Air Valve

Service the air valve as follows. See Fig. 5.

1. **Relieve the fluid pressure**, and disconnect air line from the pump.

### **WARNING**

To reduce the risk of serious injury whenever you are instructed to relieve pressure, always follow the **Pressure Relief Procedure** on page 8.

2. Remove the four screws (14) that hold the valve cover (7) on the center housing (1).
3. Remove the valve block (4) and valve carriage (2), and replace the u-cups (3). Replace the valve carriage and valve block. When you replace the valve carriage, position it all the way to one side or the other.

**NOTE:** The valve block shown in Fig. 5 is for pumps with an air-operated air motor. If your pump has a solenoid-operated air motor, this step does not pertain. Items 2, 3, 4, 16, and 17 are not required.

4. Clean any parts that are dirty.
5. To reinstall the valve cover (7), spread cover apart enough not to damage the square ring packings (6) and slide cover (7) into the center section.
6. Install the screws (14), and torque to 40 to 45 in-lb (4.5 to 5.0 N•m). See **Torque Sequence** on page 18.
7. Reconnect the pump.

 Lips of u-cups (3) must face toward each other (toward center of valve carriage (2)).

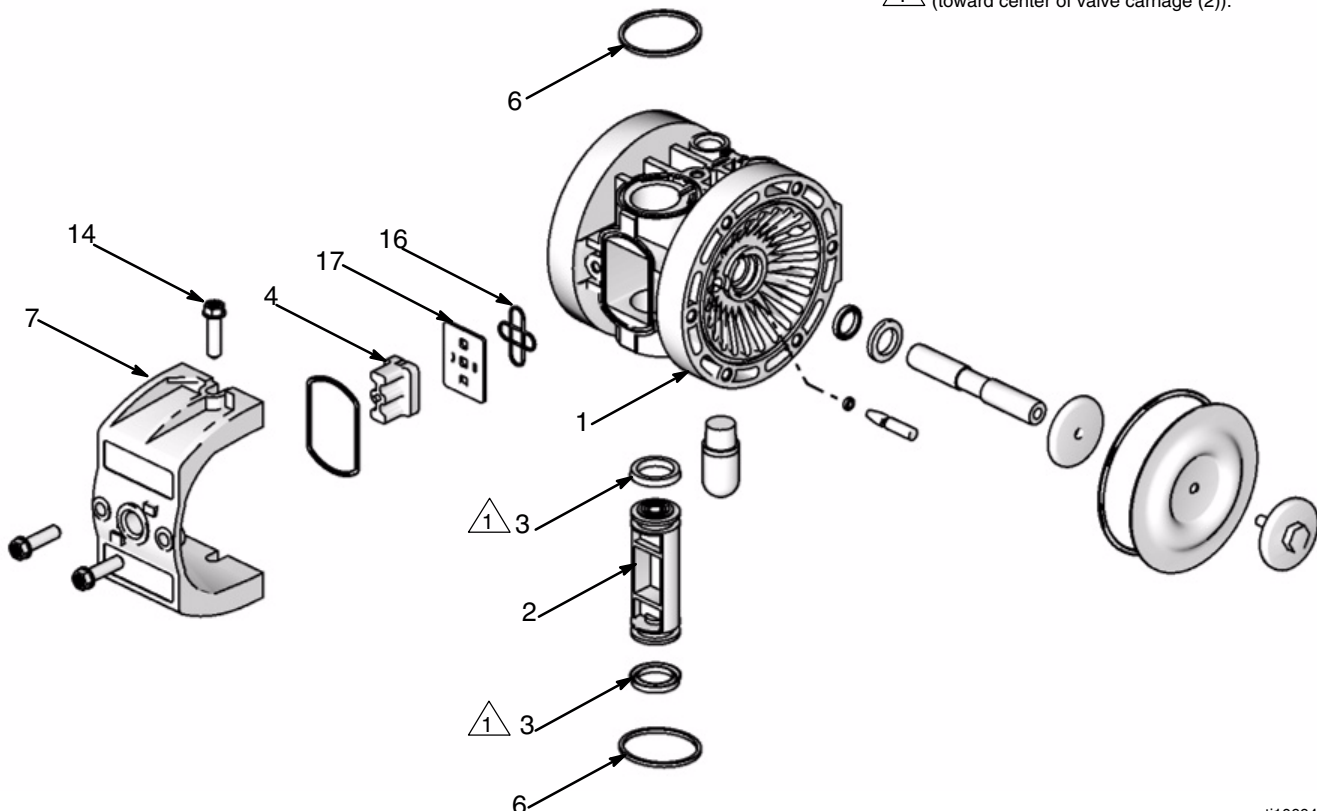

Fig. 5

ti10664a

# Service

## Replacing Diaphragms

Replace the diaphragms as follows. See Fig. 6 and Fig 7.

1. **Relieve the pressure**, and disconnect the air line from the pump.

### **WARNING**

To reduce the risk of serious injury whenever you are instructed to relieve pressure, always follow the **Pressure Relief Procedure** on page 8.

2. Remove the eight screws (58) that fasten the two fluid covers (51) to manifold (52), and remove the fluid cover/center housing assembly from the manifold.
3. Remove the six screws (58) that fasten each fluid cover (51) to the center housing (1), and pull the fluid covers off of the center housing.
4. Remove the diaphragm plates (50) from the shaft (10), and remove the diaphragms (30), and air-side diaphragm plates (11).
5. Remove the diaphragm pins (8), remove and replace the o-rings (9), and reinstall the diaphragm pins in the center housing (1).
6. Reinstall the diaphragm shaft (10).
7. Install the new diaphragms (30) with the concave side toward the center housing (1).
8. Screw the diaphragm plates (50) onto the shaft (10), and torque to 28–33 in-lb (3.2–3.7 N•m).
9. Reinstall the fluid covers (51) on the center housing (1), install the screws (58) that fasten the fluid covers to the center housing, and torque to 42–47 in-lb (4.7–5.3 N•m). See **Torque Sequence** on page 18.
10. Reinstall the fluid covers/center housing assembly on the manifold (52), install the screws (58) that fasten the fluid covers/center housing assembly to the manifold, and torque to 42–47 in-lb (4.7–5.3 N•m). See **Torque Sequence** on page 18.
11. Reconnect the pump.

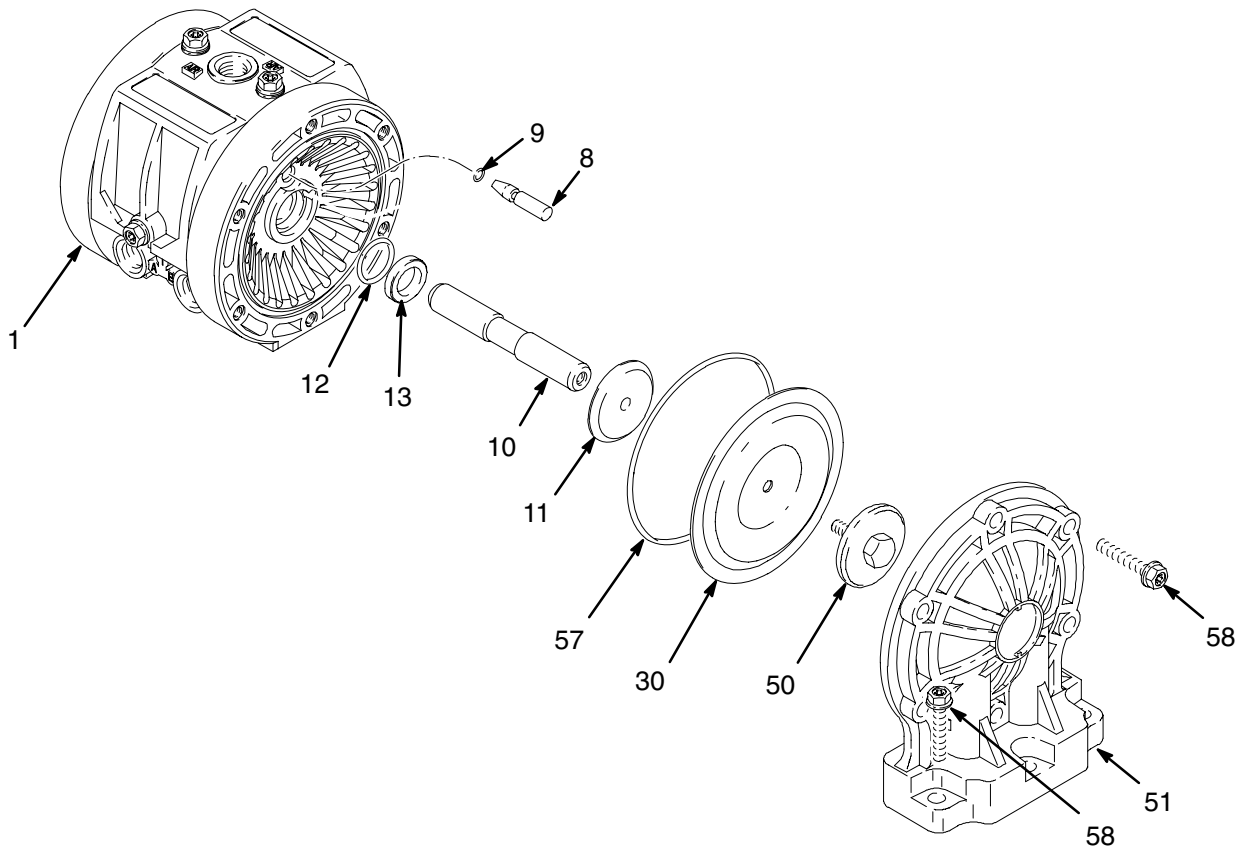

Fig. 6

06180D

# Service

## Replacing Check Valves

Replace each pair of check valves as follows. See Fig. 7.

1. **Relieve the pressure**, and disconnect the air line from the pump.

### **⚠ WARNING**

To reduce the risk of serious injury whenever you are instructed to relieve pressure, always follow the **Pressure Relief Procedure** on page 8.

2. Remove the eight screws (58) that hold the fluid cover/center housing assembly on the manifold (52), and lift the manifold covers/center housing assembly off of the manifold (52).

3. Remove and replace the check valves (20), **being careful to orient each check valve exactly like the one it is replacing**. Make sure the check valve/seat area is clean.

4. Remove and replace the sealing o-rings (21). Once compressed, o-rings may not be reused. Make sure the check valve/seat area is clean.

5. Reinstall the fluid covers/center housing assembly on the manifold (52), install the screws (58) that fasten the fluid covers/center housing assembly to the manifold, and torque to 42–47 in-lb (4.5–5.0 N•m). See **Torque Sequence** on page 18.

6. Reconnect the pump.

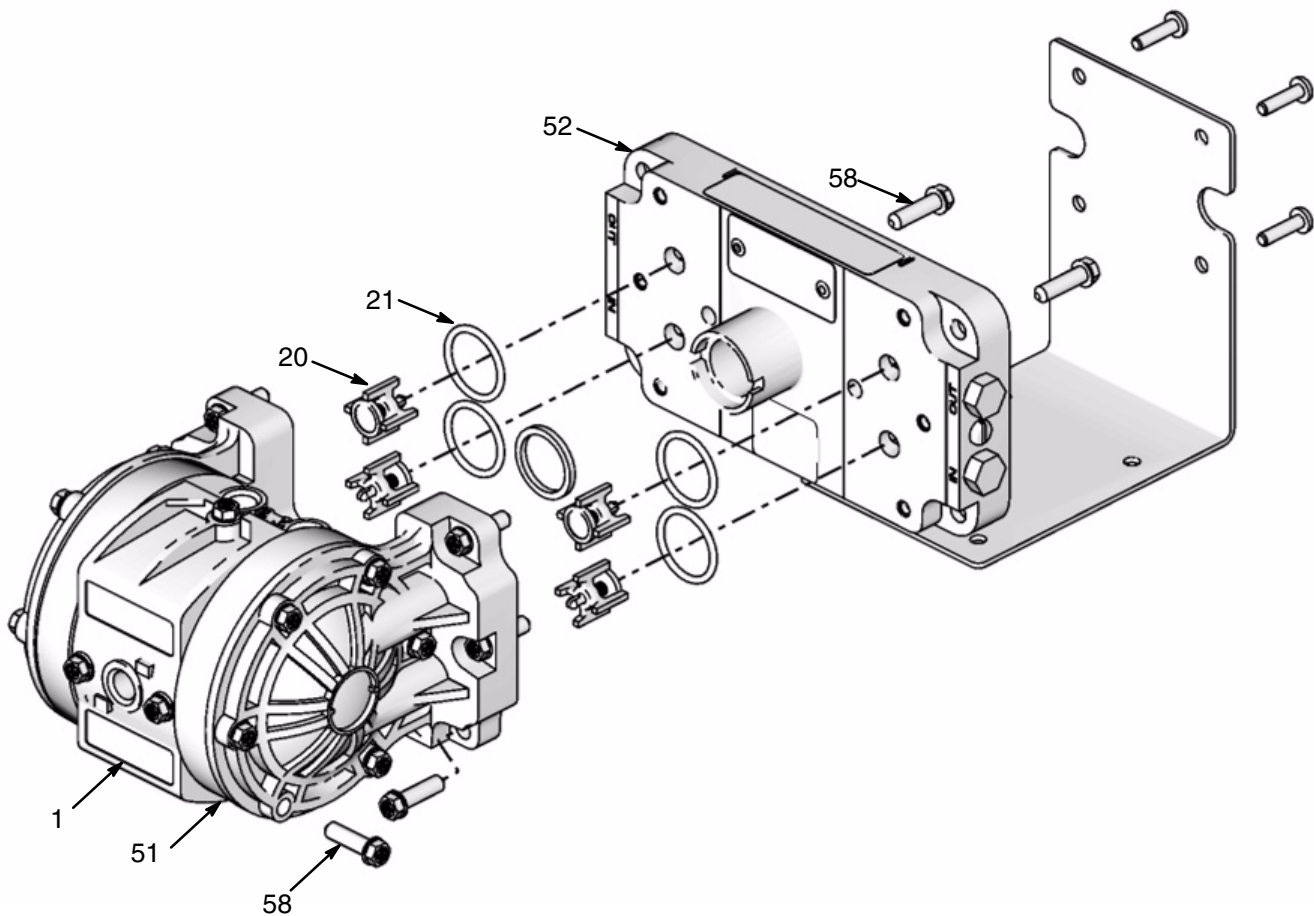

Fig. 7

ti10665a

# Parts Matrix

## Husky 205 Polypropylene, Acetal\*, and PVDF Pumps

The Model Number of your pump is marked on the pump's serial plate. To determine the Model Number of your pump from the following matrix, select the six digits that describe your pump, working from left to right. The first digit is always **D**, designating Husky diaphragm pumps. The remaining five digits define the materials of construction. For example, a pump with a Husky 205 polypropylene air motor, polypropylene fluid section, polypropylene check valves, and PTFE diaphragms is Model **D 1 2 0 9 1**. To order replacement parts, refer to the **Part Lists** on pages 16 and 17. *The digits in the matrix do not correspond to the reference numbers in text, **Parts Drawings**, or **Parts Lists**.*

Diaphragm Pump	Air Motor	Fluid Section	Seats and Guides	Checks	Diaphragms
D (for all pumps)	1 (Husky 205; polypropylene, standard) 2 (Husky 205; polypropylene, for solenoid operation) M (Husky 205; polypropylene, standard with fluoroelastomer o-rings on actuator pin)	1 (acetal)* 2 (polypropylene) 3 (not used) 4 (not used) 5 (PVDF)	0 (no seats/guides)	2 (acetal) A (PVDF) 9 (polypropylene)	1 (PTFE) 6 (Santoprene®)

\*  II 2 G Certified

# Service Kit Matrix

## Air Valve and Fluid Section Service Kits for Husky 205 Pumps

To determine the Model Number of your service kit from the following matrix, select the six digits that describe your pump, working from left to right. The first digit is always **D**, designating Husky diaphragm pumps. The second digit is always 0 (zero), and the third digit is always 1 (one). The remaining five digits define the materials of construction. For example, if your pump has polypropylene checks and PTFE diaphragms, order Repair Kit **D 0 1 0 9 1**. If you only need to repair certain parts (for example, the diaphragms), use the 0 (null) digit for the balls, and order Repair Kit **D 0 1 0 0 1**. To order replacement parts, refer to the **Part Lists** on pages 16 and 17. *The digits in the matrix do not correspond to the reference numbers in text, **Parts Drawings**, or **Parts Lists**.*

Diaphragm Pump	Air Motor	O-rings	Seats	Checks	Diaphragms
D (for all pumps except DMXXXX)	0 (for all pumps except DMXXXX)	1 (for all pumps except DMXXXX)	0 (for all pumps except DMXXXX)	0 (null) A (PVDF) 2 (acetal) 9 (polypropylene)	0 (null) 1 (PTFE) 6 (Santoprene®)

# Parts

## Air Motor Section (matrix column 2)

Digit	Ref. No.	Part No.	Description	Qty.
1	1	240898	HOUSING, center, assembly (includes 12, 13, and 57)	1
	2	191157	CARRIAGE, valve	1
	3	113869	SEAL, u-cup	2
	4	194533	VALVE BLOCK (for pump with air-operated air motor)	1
	5	191160	GASKET, molded	1
	6	115056	O-RING, packing	2
	8	191021	PIN, actuator	2
	9	113565	O-RING, packing	2
		103557	O-RING, packing (DMXXXX pumps only)	2
	10	193778	SHAFT, diaphragm	1
	11	193775	PLATE, diaphragm, air side	2
	12	114710	O-RING, diaphragm shaft	2
	13	15J176	BEARING, retaining	2
	14	113341	SCREW, torx	4
	15	114174	MUFFLER, porous plastic	1
	16	194386	SEAL, valve plate	1
	17	194384	PLATE, valve	1
2	1	240899	HOUSING, center, assembly (includes 12, 13, and 57)	1
	10	193778	SHAFT, diaphragm	1
	11	193775	PLATE, diaphragm, air side	1
	12	114710	O-RING, diaphragm shaft	2
	13	15J176	BEARING, retaining	2
	14	113341	SCREW, torx	4
	15	114174	MUFFLER, porous plastic	1

## Fluid Section (matrix column 3)

Digit	Ref. No.	Part No.	Description	Qty.
1	7	191140	COVER, valve	1

	49	290229	LABEL, warning	1
	50	191553	PLATE, diaphragm; acetal	2
	51	276474	COVER, fluid; acetal	2
	52	276471	MANIFOLD; acetal	1
	53	113576	PLUG, port; acetal	2
	54	100264	SCREW, grounding	2
	55	100179	NUT, hex , grounding	2
	57	113570	O-RING, packing	2
	58	113341	SCREW, torx	20
	59	115055	O-RING, exhaust	1
	60	194986	BRACKET, mounting	1
61	111630	SCREW, machine, pn hd	4	
2	7	191140	COVER, valve	1
	49	290229	LABEL, warning	1
	50	191141	PLATE, diaphragm; polypropylene	2
	51	276473	COVER, fluid; polypropylene	2
	52	276470	MANIFOLD; polypropylene	1
	53	113577	PLUG, port; polypropylene	2
	57	113570	O-RING, packing	2
	58	113341	SCREW, torx	20
	59	115055	O-RING, exhaust	1
	60	194986	BRACKET, mounting	1
	61	111630	SCREW, machine, pn hd	4
5	7	191140	COVER, valve	1
	49	290229	LABEL, warning	1
	50	191554	PLATE, diaphragm; PVDF	2
	51	276475	COVER, fluid; PVDF	2
	52	276472	MANIFOLD; PVDF	1
	53	113447	PLUG, port; PVDF	2
	57	113570	O-RING, packing	2
	58	113341	SCREW, torx	20
	59	115055	O-RING, exhaust	1
	60	194986	BRACKET, mounting	1
	61	111630	SCREW, machine, pn hd	4



# Parts

## Check Valve (matrix column 5)

Digit	Ref.	Part No.	Description	Qty.
2	20	241134	VALVE, check; acetal	4
	21	113566	O-RING, packing	4
9	20	240896	VALVE, check; polypropylene	4
	21	113566	O-RING, packing	4
A	20	240897	VALVE, check; PVDF	4
	21	113566	O-RING, packing	4

## Diaphragm (matrix column 6)

Digit	Ref.	Part No.	Description	Qty.
1	30	191402	DIAPHRAGM; PTFE (for all Husky 205 pumps)	2
6	30	196385	DIAPHRAGM; Santoprene®	2

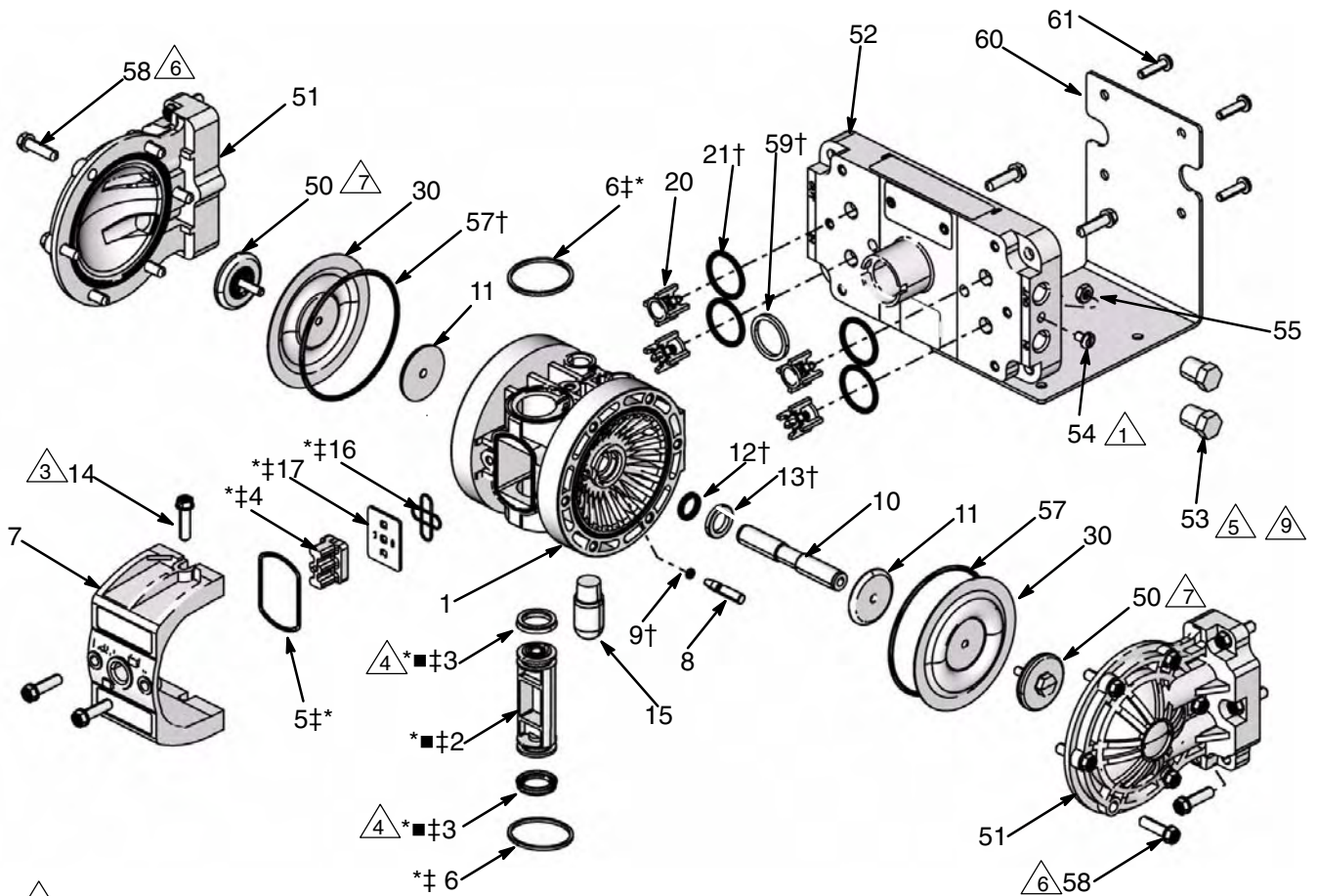

△1 Used on acetal models only.

△3 Torque to 40–45 in-lb (4.5–5.0 N•m). See **Torque Sequence** on page 18

△4 Lips of u-cups (3) must face toward each other, toward center of valve carriage (2).

△5 Torque to 20 in-lb (2.2 N•m).

△6 Torque to 42–47 in-lb (4.7–5.3 N•m). See **Torque Sequence** on page 18.

△7 Torque to 28–33 in-lb (3.2–3.7 N•m). See **Torque Sequence** on page 18.

△9 Not assembled. These plugs are supplied to plug the two ports in the manifold that are not used.

■ These parts cannot be ordered separately. They come preassembled and are included as part of the Air Valve Service Kit 238853.

\* These parts are included in Air Valve Service Kit 238853, which may be purchased separately.

† These parts are included in Fluid Section Service Kit. D010xx, which may be purchased separately.

‡ These parts are included in pump with integral air valve only.

ti10666a

# Torque Sequence

For proper installation, always follow torque sequence whenever you are instructed to torque screws.

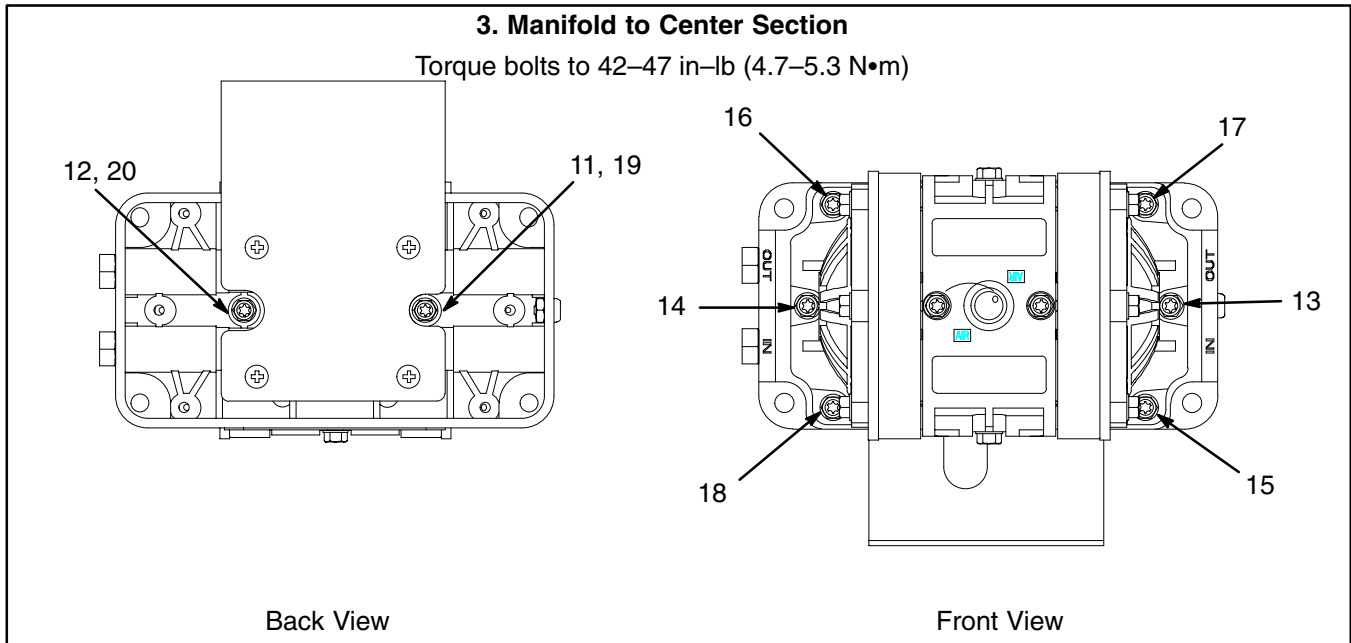
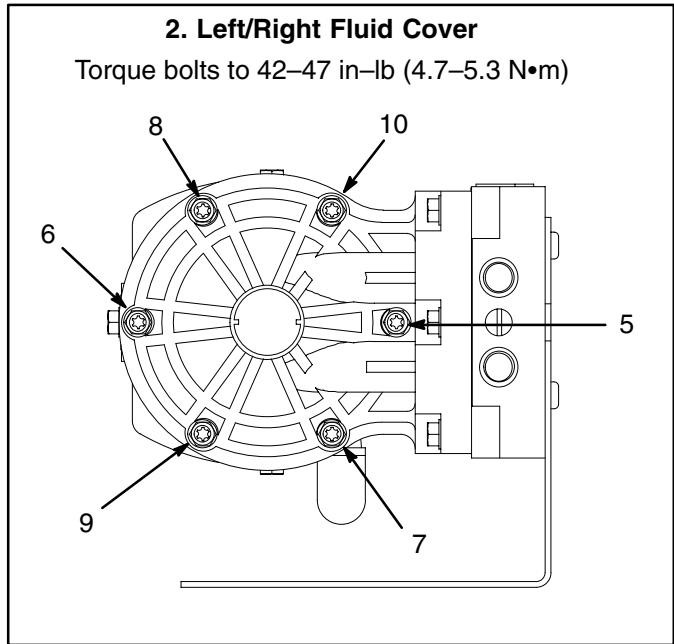
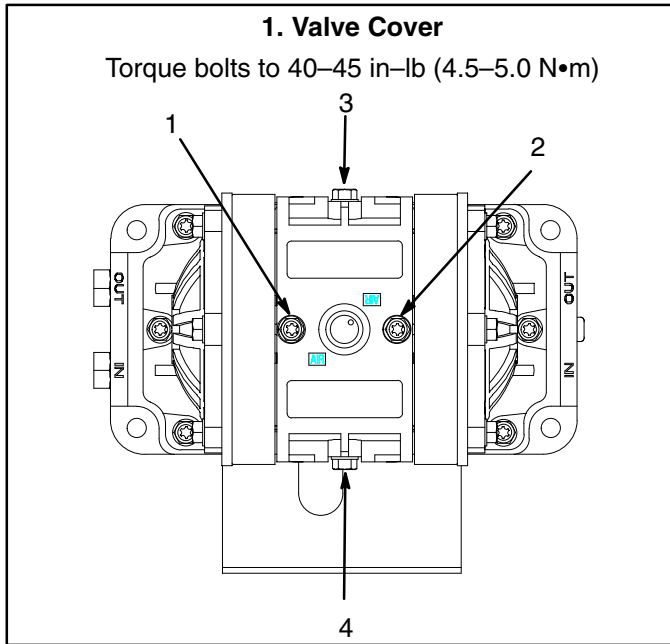

# Technical Data

Maximum fluid working pressure	100 psi (0.7 MPa, 7 bar)
Maximum/minimum air pressure	100 psi/20psi (0.7 MPa, 7 bar)/(0.14 MPa, 1.4 bar)
Maximum fluid flow	5.0 gpm (18.9 lpm)
Maximum pump speed	320(dry) cycles per minute 250(wet) cycles per minute
Volume per stroke*	0.006 gal (23 cc)
Volume per cycle*	0.012 gal (46 cc)
Maximum suction lift dry	8 to 10 ft (2.5 to 3 m)
Maximum size pumpable solids	0.06 in. (1.5 mm)
Maximum operating temperature	180° F (82° C)
Maximum air consumption	9.0 scfm (0.252 m <sup>3</sup> /min.)
Air inlet size**	1/4 npt(f) / 1/4 bsp(f)
Fluid inlet size**	1/4 npt(f) / 1/4 bsp(f)
Fluid outlet size**	1/4 npt(f) / 1/4 bsp(f)
Air exhaust port size**	1/4 npt(f) / 1/4 bsp(f)

Weight	
Polypropylene pump	2.0 lb (0.9 kg)
Acetal pump	2.5 lb (1.1 kg)
PVDF pump	2.8 lb (1.3 kg)
Wetted parts ( housings, diaphragms, check valves)	
Polypropylene pump:	
Glass-filled polypropylene, PTFE, polypropylene	
Acetal pump:	
Acetal with SST fibers, PTFE, acetal	
PVDF pump:	
PVDF, PTFE, PVDF	
Sound power level (pressure) (per ANSI STD S12.1)	
at 100 psi (0.7 MPa, 7 bar)	75.5 dBa
at 70 psi (0.49 MPa, 4.9 bar)	72.0 dBa
at 40 psi (0.28 MPa, 2.8 bar)	68.2 dBa
Sound power level (intensity) (per ANSI STD S12.1)	
at 100 psi (0.7 MPa, 7 bar)	84.5 dBa
at 70 psi (0.49 MPa, 4.9 bar)	81.1 dBa
at 40 psi (0.28 MPa, 2.8 bar)	76.6 dBa

\* Volume per cycle may vary based on suction condition, discharge head, air pressure, and fluid.

\*\* Hybrid thread allows for either 1/4 npt or 1/4 bsp fitting.

PVDF is a registered trademark of Atochem North America, Incorporated.

Schrader Bellows® is a registered trademark of Schrader Bellows.

Santoprene® is a registered trademark of the Monsanto Company.

# Dimensions and Mounting Hole Layout

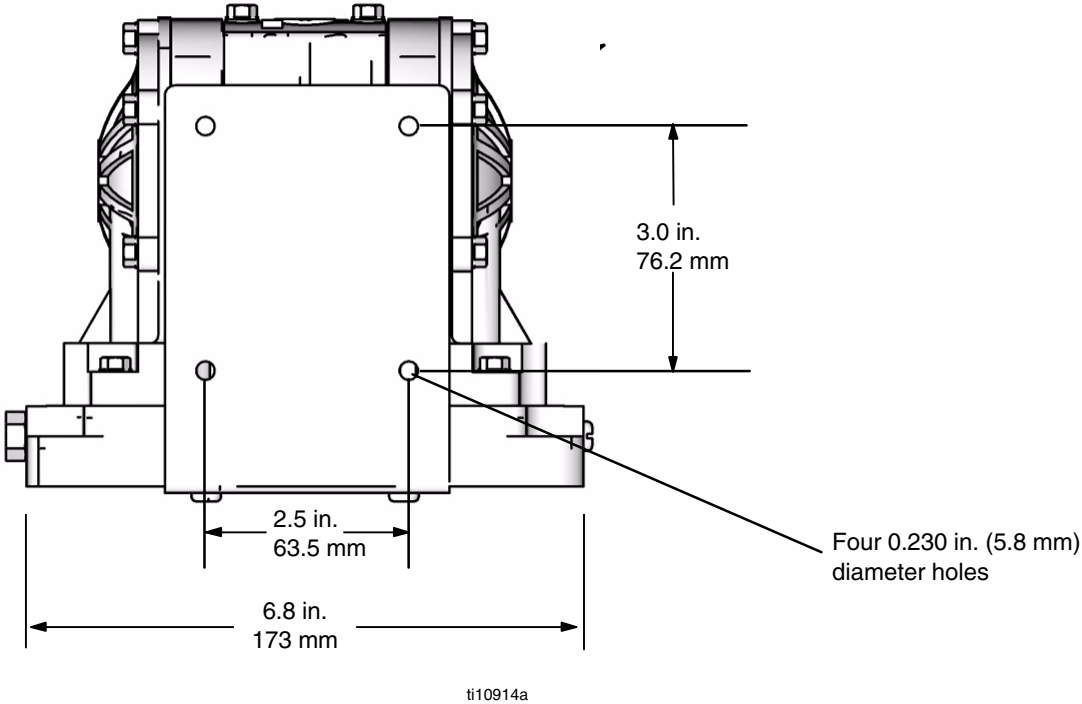
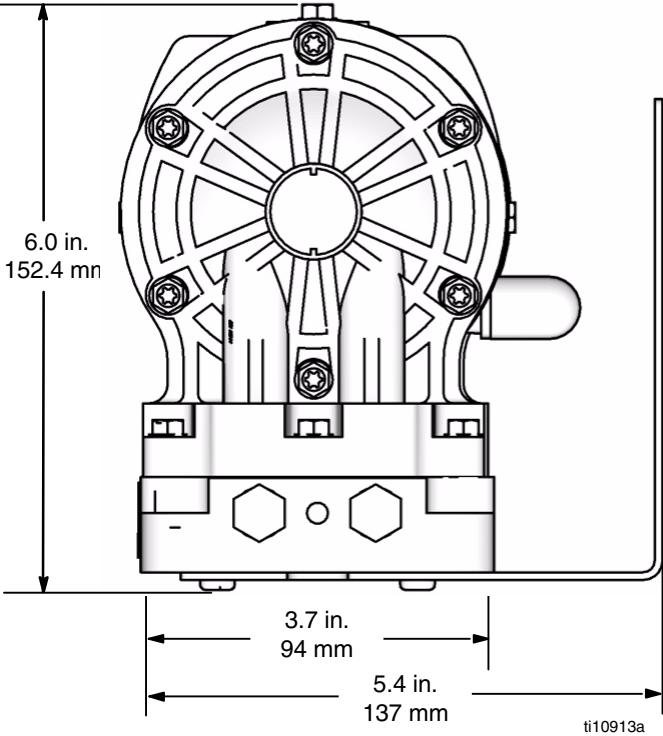

# Performance Charts

## Husky 205 Fluid Outlet Pressure

**Test Conditions:** Pump tested in water with inlet submerged.

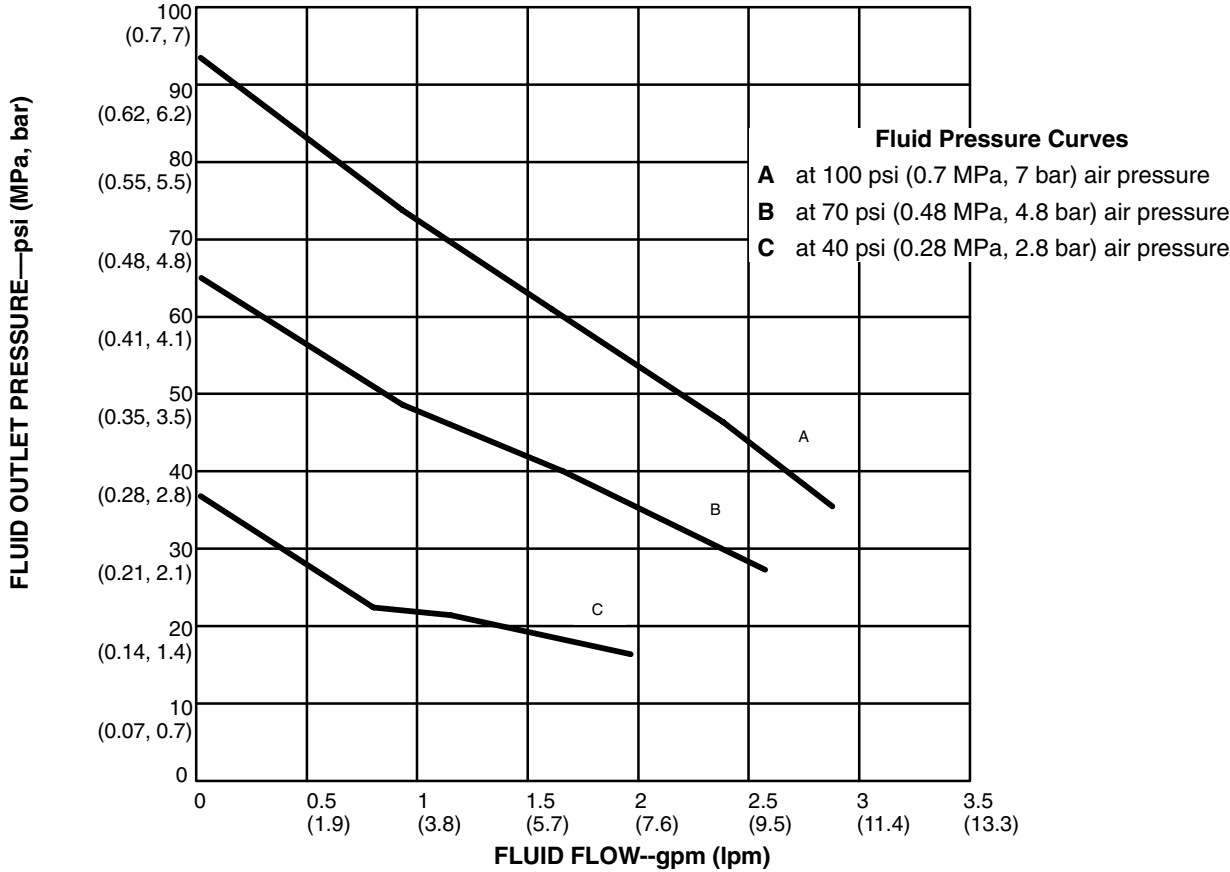

To find Fluid Outlet Pressure (psi/MPa/bar) at a specific fluid flow (gpm/lpm) and operating air pressure (psi/MPa/bar):

1. Locate fluid flow rate along bottom of chart.
2. Follow vertical line up to intersection with selected fluid outlet pressure curve.
3. Follow left to scale to read fluid outlet pressure.

# Performance Charts

## Husky 205 Air Consumption

**Test Conditions:** Pump tested in water with inlet submerged.

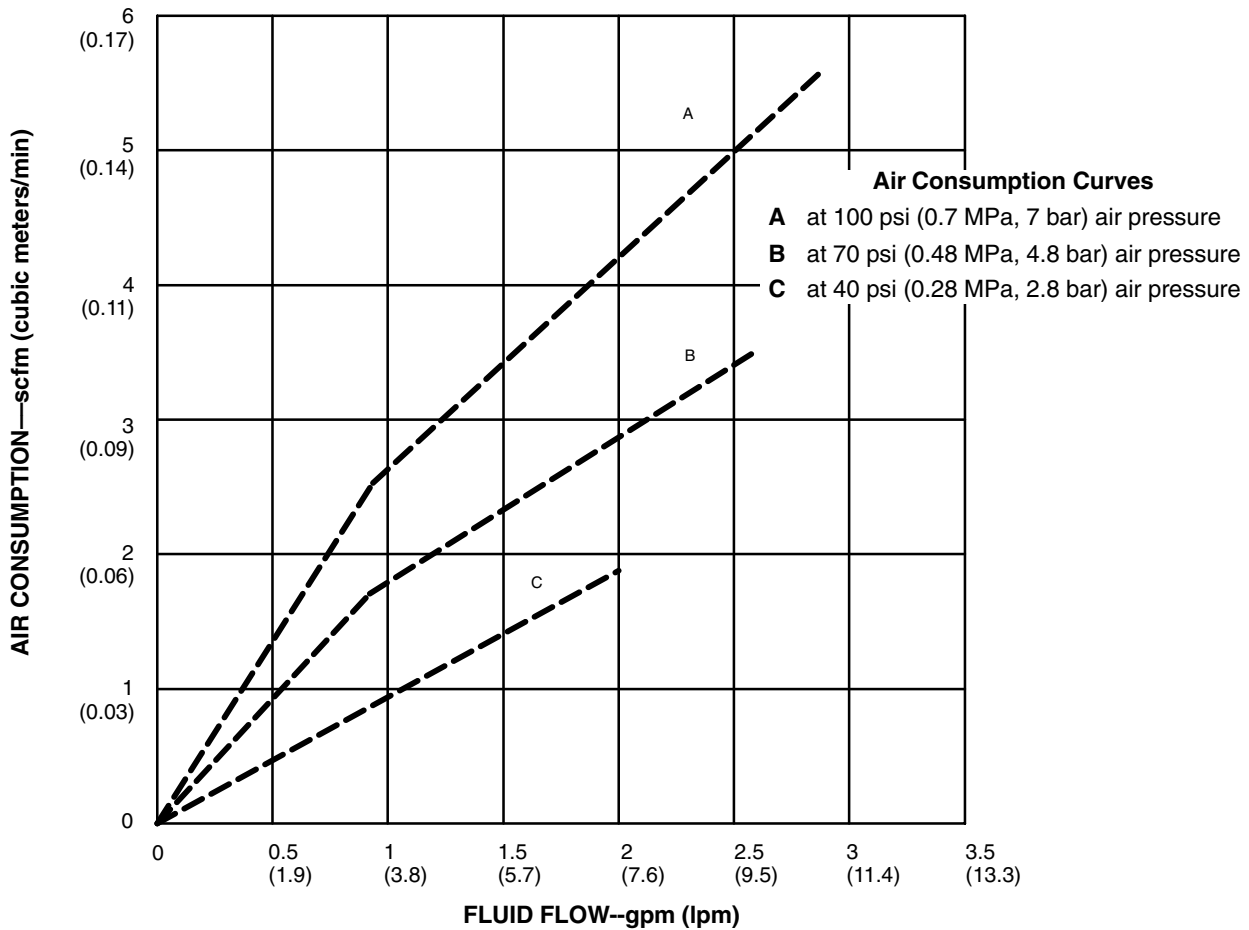

**To find Pump Air Consumption** (scfm or m<sup>3</sup>/min) at a specific fluid flow (gpm/lpm) and air pressure (psi/MPa/bar):

1. Locate fluid flow rate along bottom of chart.
2. Read vertical line up to intersection with selected air consumption curve.
3. Follow left to scale to read air consumption.



# Graco Warranties

## Graco Standard Husky Pump Warranty

Graco warrants all equipment manufactured by Graco and bearing its name to be free from defects in material and workmanship on the date of sale to the original purchaser for use. With the exception of any special, extended, or limited warranty published by Graco, Graco will, for a period of five years from the date of sale, repair or replace any part of the equipment determined by Graco to be defective. This warranty applies only when the equipment is installed, operated and maintained in accordance with Graco's written recommendations.

This warranty does not cover, and Graco shall not be liable for general wear and tear, or any malfunction, damage or wear caused by faulty installation, misapplication, abrasion, corrosion, inadequate or improper maintenance, negligence, accident, tampering, or substitution of non-Graco component parts. Nor shall Graco be liable for malfunction, damage or wear caused by the incompatibility of Graco equipment with structures, accessories, equipment or materials not supplied by Graco, or the improper design, manufacture, installation, operation or maintenance of structures, accessories, equipment or materials not supplied by Graco.

This warranty is conditioned upon the prepaid return of the equipment claimed to be defective to an authorized Graco distributor for verification of the claimed defect. If the claimed defect is verified, Graco will repair or replace free of charge any defective parts. The equipment will be returned to the original purchaser transportation prepaid. If inspection of the equipment does not disclose any defect in material or workmanship, repairs will be made at a reasonable charge, which charges may include the costs of parts, labor, and transportation.

**THIS WARRANTY IS EXCLUSIVE, AND IS IN LIEU OF ANY OTHER WARRANTIES, EXPRESS OR IMPLIED, INCLUDING BUT NOT LIMITED TO WARRANTY OF MERCHANTABILITY OR WARRANTY OF FITNESS FOR A PARTICULAR PURPOSE.**

Graco's sole obligation and buyer's sole remedy for any breach of warranty shall be as set forth above. The buyer agrees that no other remedy (including, but not limited to, incidental or consequential damages for lost profits, lost sales, injury to person or property, or any other incidental or consequential loss) shall be available. Any action for breach of warranty must be brought within six years of the date of sale.

Graco makes no warranty, and disclaims all implied warranties of merchantability and fitness for a particular purpose in connection with accessories, equipment, materials or components sold but not manufactured by Graco. These items sold, but not manufactured by Graco (such as electric motors, switches, hose, etc.), are subject to the warranty, if any, of their manufacturer. Graco will provide purchaser with reasonable assistance in making any claim for breach of these warranties.

In no event will Graco be liable for indirect, incidental, special or consequential damages resulting from Graco supplying equipment hereunder, or the furnishing, performance, or use of any products or other goods sold hereto, whether due to a breach of contract, breach of warranty, the negligence of Graco, or otherwise.

### **FOR GRACO CANADA CUSTOMERS**

The parties acknowledge that they have required that the present document, as well as all documents, notices and legal proceedings entered into, given or instituted pursuant hereto or relating directly or indirectly hereto, be drawn up in English. Les parties reconnaissent avoir convenu que la rédaction du présente document sera en Anglais, ainsi que tous documents, avis et procédures judiciaires exécutés, donnés ou intentés à la suite de ou en rapport, directement ou indirectement, avec les procédures concernées.

## Extended Product Warranty

Graco warrants all Husky 205, 307, 515, 716, 1040, 1590, 2150, and 3275 air valve center sections to be free from defects in material and workmanship for a period of fifteen years from date installed in service by the original purchaser. Normal wear of items such as packings or seals are not considered to be defects in material and workmanship.

Five years	Graco will provide parts and labor.
Six to Fifteen years	Graco will replace defective parts only.

# Graco Information

**TO PLACE AN ORDER**, contact your Graco distributor, or call one of the following numbers to identify the distributor closest to you:

**1-800-328-0211 Toll Free**

**612-623-6921**

**612-378-3505 Fax**

*All written and visual data contained in this document reflects the latest product information available at the time of publication. Graco reserves the right to make changes at any time without notice.*

This manual contains English. MM 308652

**Graco Headquarters:** Minneapolis

**International Offices:** Belgium, China, Japan, Korea

**GRACO INC. P.O. BOX 1441 MINNEAPOLIS, MN 55440-1441**

**www.graco.com**

308652 10/1996, Revised 08/2007